



WG100PT 90 KVA Ground Power Units provide regulated 400 Hz power to all types of jet aircraft. The unit features a brushless revolving field generator. The trailer-mounted units utilize a spring mounted chassis of rugged steel construction with fifth wheel steering. The units provide low noise operation.

GENERATOR SPECIFICATIONS:

400Hz 115/200 volt nominal, +/-10% adjustable, 3 phase (0.8PF), 4 wire wye revolving field, brushless, self-cooling, permanently lubricated dual bearings, brushless rotating rectifier assembly, directly coupled to the engine. Engine and Generator vibration mounted.

ENGINE SPECIFICATIONS:

Cummins 6BTA5.9, 160Hp (120kw) at 2000 RPM including, dry type air cleaner, full flow fuel and lube oil filters, muffler, heavy-duty radiator, blower type fan, battery charge alternator.

ENGINE CONTROLS/INSTRUMENTS:

Isochronous electronic governor, 24 volt battery, ammeter, oil pressure gauge, running time meter, temperature gauge, fuel gauge, low oil pressure and high coolant temperature protection. Automatic shut-down for high temperature, low oil pressure

. OPTIONAL EQUIPMENT

GENERATOR CONTROLS:

Frequency meter, ammeter, voltmeter, voltmeter-ammeter selector switch, automatic voltage regulator, line drop compensator, overload relay, solid-state over/under voltage relay and over/under frequency relay, plug interlock relay, test switch, and fault annunciator with lamp test switch.

ELECTRICAL CHARACTERISTIC

- **VOLTAGE REGULATION:** +/-1% over full range of generator loading
- **VOLTAGE MODULATION:** +/- .5% volt at steady state.
- **FREQUENCY REGULATION:** +/- 1% from
- **TRANSIENTS: (no load to full load)**
 - FREQUENCY:** 2.5% recovery 1 sec.
 - VOLTAGE:** +/- 15% Recovery time less than 0.1 sec.
- **LINE DROP COMPENSATION:** 10 volts, line to neutral
- **OVERLOAD:** 125% for 5 min.
- **HARMONICS:** less than 2% total harmonic content.
- **ELECTRICAL PERFORMANCE:** well within MIL-STD-704, ISO6858, GJB549-88

- Transformer rectifier 28 VDC
- Single/dual or 56VDC
- Cold weather starting kit.

KVA	P.F	Rated Amps	Engine				Dimensions
			Manufacturer	Model	HP	RPM	
90	0.8	260A	CUMMINS	6BTA5.9	160	2000	128x66x73 in. (3255x1680x1850)mm

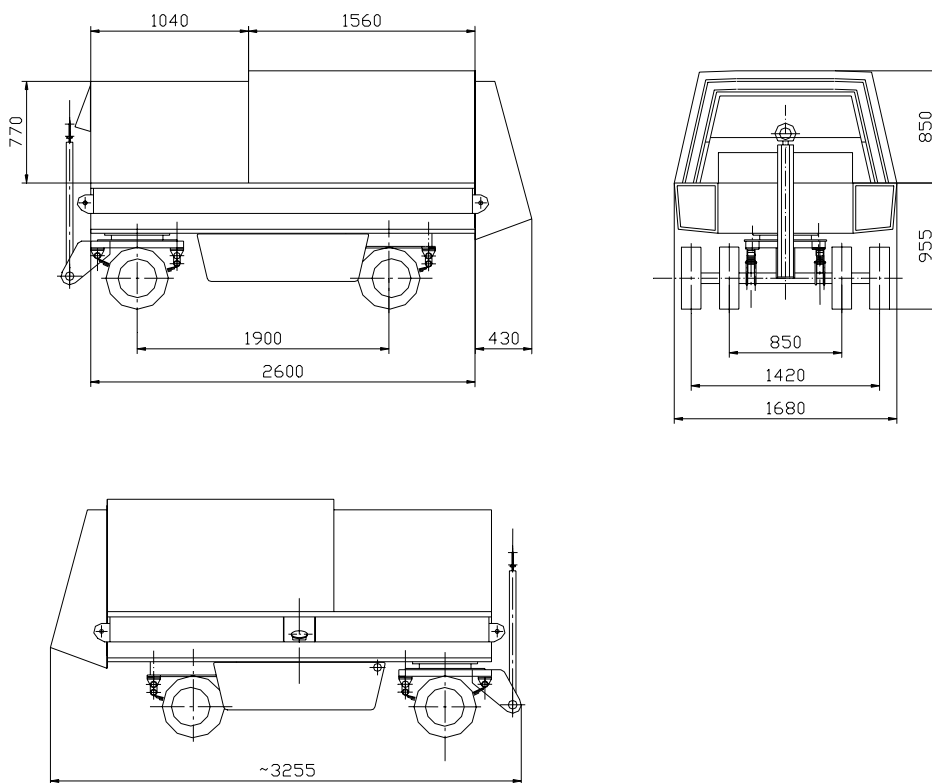

Revised Dec 2003

SPECIFICATIONS TO CHANGE WITHOUT NOTICE



WEIHAI GUANGTAI AIRPORT EQUIPMENT CO.,LTD.
 160 Guzhai South Road, Weihai, Shandong, 264200,
 Tel: 86-631-5251465 Fax: 86-631-5251451/5251565
 Web: www.guangtai.com.cn